



Hall Effect Magnetic Sensors Ø 18



HALL EFFECT MAGNETIC PROXIMITY SENSORS 12÷30 VDC PNP OUTPUT

- Three-wire sensors
- Fast 50 µS ON/OFF
- Sensing models: *Front end travel*
Bilateral side travel
- Choice of magnet targets
- PNP NC or NO

HS Series



Identification code

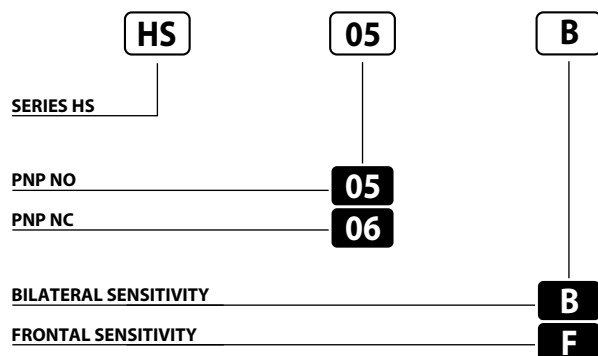

Wiring diagrams

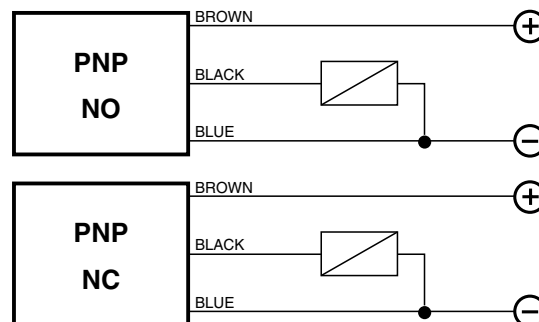

| MAGNETIC FLUX (Gauss) | |
|----------------------------|---|
| • SENSOR ON | ≥ 25 (Tip. 15 at 25°C) |
| • SENSORE OFF | ≥ 5 (Tip. 11 at 25°C) |
| • HYSTERESIS | Max. diff. 7 (Tip. 4 at 25°C) |
| NOMINAL VOLTAGE | 12 ÷ 30 VDC (-15/+10%) |
| RESIDUAL RIPPLE | ≤ 10% |
| MAX. CURRENT OUTPUT | 200 mA |
| ABSORPTION AT 30 VDC | ≤ 10 mA |
| VOLTAGE DROP (Sensor ON) | < 1.8 V |
| YELLOW LED | Output indicator |
| GREEN LED | Supply indicator |
| SWITCHING FREQUENCY (max.) | 10 kHz |
| TIME RESPONSE | 100 µS |
| START UP DELAY | 50 mS |
| SHORT CIRCUIT PROTECTION | Present (self-resetting) |
| ELECTRIC PROTECTIONS | Against reversal polarity - inductive loads |
| TEMPERATURE LIMITS | - 20 ÷ +60 °C |
| PROTECTION DEGREE | IP 67 |
| CABLE LENGTH | 2 m |
| CABLE SECTION | 3 x 0.25 mm ² |
| HOUSING MATERIAL | Nickel-plated brass |
| WEIGHT (Approximately) | 145 g |

Hall effect sensor / magnet switching distance (mm)

| Distance | Hysteresis | Magnet Model |
|----------|------------|--------------|
| 33 | 4 | MG01 |
| 30 | 4 | MG02 |
| 18 | 5 | MG03 |
| 41 | 6,5 | MG04 |
| 35 | 7 | MG05 |

WARNING: The data specified in this table have an approximate value because they depend on the magnet position, on the material on which it is applied (ferromagnetic or not) and because they are related to the magnet during the frontal approach.

Dimensions (mm)

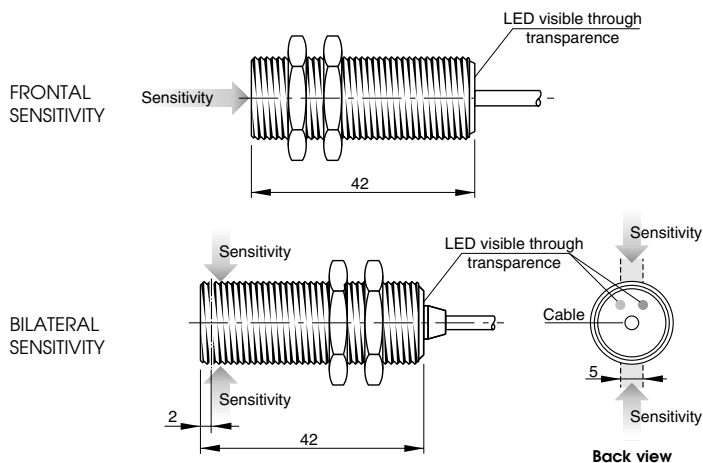

Magnets dimensions (mm)

